

E24 Electric

Char-Broiler



EmberGlo®

E24 Electric Char-Broilers



*Electric Char Broiler
Model E2412*



*Electric Char Broiler
Model E2436*

Operational Safety

Because EmberGlo's heating elements are recessed into the bottom of the grate, they are protected from fats and corrosive juices. As a result, they last 100% longer than elements on many competitive units. At the same time, the recessed design absolutely prevents the danger of flare-up.

More Usable Grill Space

EmberGlo features an unsurpassed 655 square inches of net, usable grill space for the 36" model. The completely flexible 36" unit, for example, is three 12" grate modules with three separate temperature controls (ideal for different thicknesses of steaks, burgers, etc.). You can operate one 12" section during slack periods and turn on the other sections as you need them during lunch or dinner hours.

Broiling is Fast

Prepare a perfectly branded hamburger in 4 minutes or charbroil an 8 ounce refrigerated strip sirloin in as little as 7 minutes! Compare this to any competitive 36" model, and you'll see why EmberGlo offers more production capacity in the same amount of floor space.

Save on Energy Expense

Each 12" EmberGlo broiling module uses 3 kW of electrical capacity (208 or 240 VAC, single or 3-phase current) subsequently, the 36" EmberGlo electric broiler requires only a 9 kW capacity. Install a dependable and profitable charbroiling system in small spaces using the E2412 or use the same basic system and expand to fit a space of two, three or even ten or more feet wide for larger restaurants and chain operations which demand extraordinary cooking capacity. Whether you want to increase your broiling in a big way or just add a little variety to your menu, there is a place in your operation for the new E24 Series Electric Broiler from EmberGlo.





*Electric Char Broiler
Model E2424*

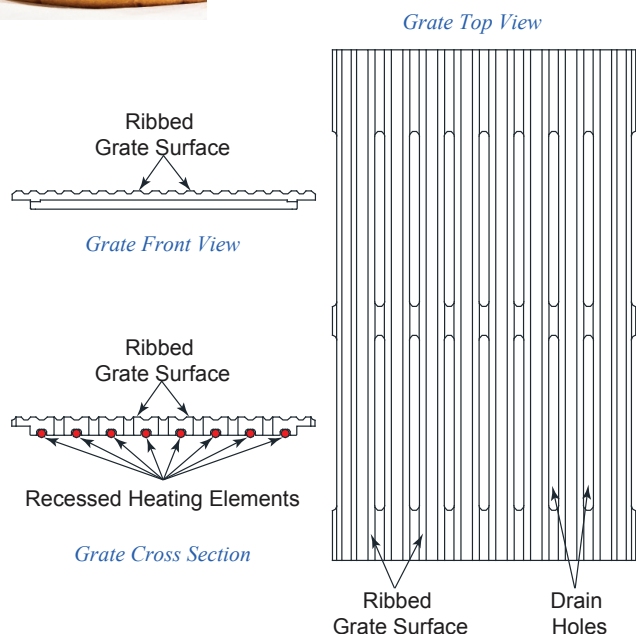

Features & Benefits

Grate Top

- Efficient heat transfer for quicker recovery
- Recessed elements prevent flare-ups
- Excessive grease drains away, entire top may be loaded
- Cast grate distributes the heat evenly
- Grate Ribs brand meat effectively without excessive charring
- Improved flavor profile with the ribbed grate surface

Turn the dial to "HI" and preheat for 20 minutes. The raised cast iron ribs brand the meat's surface and quickly transfer heat to the food's interior. Drippings are neatly deposited into a slide-out grease drawer. The remaining clean-up chores are easy too. For example, the stainless steel hopper and grease drawer can be rinsed in the kitchen sink, then simply wiped dry and clean.



Electric Broiler



- Recessed heating elements for complete flame-free broiling
- The uniformity of temperature eliminates the need for product "shifting"
- More useful broiling area per inch of width than any electric char-broiler, regardless of price
- 12" broiling modules with individual controls
- Grease-Flo drainage system and self-cleaning grate for minimum mess and clean-up time
- 100% durable stainless steel cabinet construction
- The unique EmberGlo raised rib design finishes the product with a distinctive "char-brand" without burning
- Lift out panels for faster/easier cleaning
- Minimal heat radiation into kitchen and/or dining area for greater comfort and lower air conditioning costs
- Floor model available in the E2436 only

Specifications



Model Number	Capacity	Width Inches/Millimeters	Depth Inches/Millimeters	Height Inches/Millimeters	Total kW Load-ing	Nominal Amperes Per Line *						Shipping Weight
						1 Phase		3 Phase				
						208V	240V	208V	240V	440V	480V	
E2412 ‡	Grill size 11½" x 19"; broils five 8 oz. strips or ten 4 oz. burgers per load	12/305	24/609		3	14.5	12.5					97 lbs.
E2424 ‡	Grill size 23" x 19"; broils ten 8 oz. strips or twenty 4 oz. burgers per load; 2 controls	24/609	24/609	17/435 to 18.5/473	6	28.8	25.0	25.0	21.7	11.8	10.8	150 lbs.
E2436 ‡	Grill size 34½" x 19"; broils fifteen 8 oz. strips or thirty 4 oz. burgers per load; 3 controls	36/914	24/609		9	43.2	37.5	25.0	21.7	11.8	10.8	205 lbs.
E2436F ‡ (Floor Model)	Grill size 34½" x 19"; broils fifteen 8 oz. strips or thirty 4 oz. burgers per load; 3 controls	36/914	24/609	33.9/861 to 35.4/899	9	43.2	37.5	25.0	21.7	11.8	10.8	305 lbs.

All units are shipped wired for single phase or 3-phase
Stainless top, front and sides are standard.

Optional extras: A 10" high splatter guard is available for all models. See price sheet for details. To specify or order, please indicate model number and voltage desired.

* For voltage applications other than above call the factory.

‡ Cord and plug receptacle not included with the electric broiler.

Do not install broiler closer than 5" to the back and 8" to the side walls. Legs are shipped loose with the unit and **must** be installed. Minimum leg height must be maintained for proper ventilation with no blockage around the bottom of the broiler. Failure to install or removal of the legs is a violation of the approval seals and voids the manufacturer's warranty.

Measurements in Inches and Millimeters Counter Top Models- E2412, E2424 and E2436

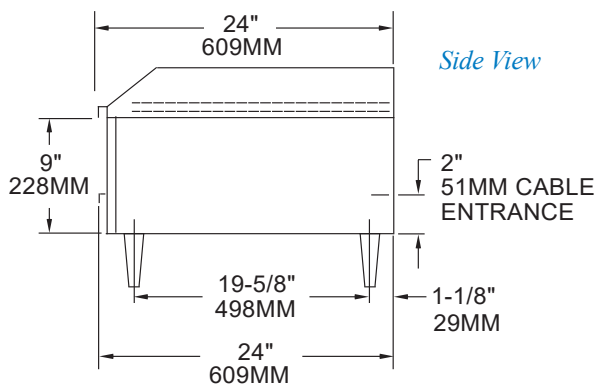
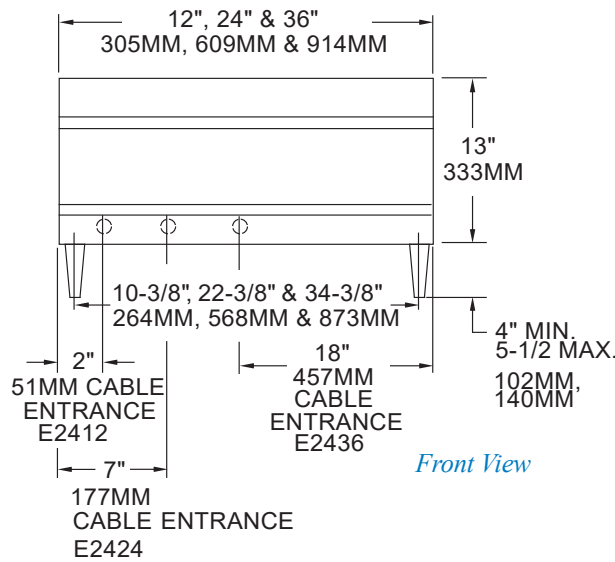

Measurements in Inches and Millimeters Floor Model - E2436F (Only available in Model E2436) Side View

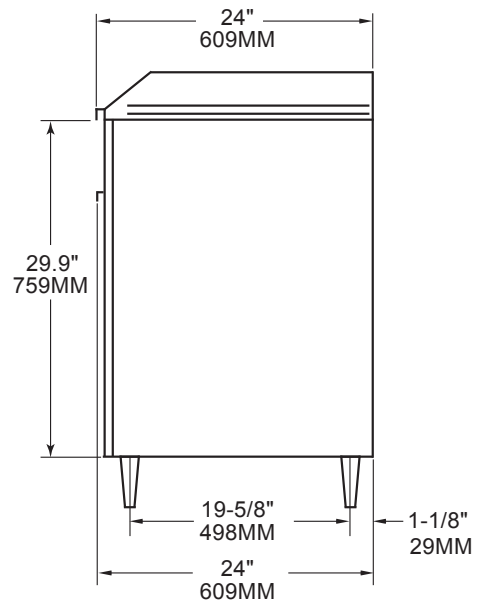

Quality Designed for Proven Performance



EmberGlo - A Division of Midco International - 4140 West Victoria Street - Chicago, Illinois 60646

toll free: 866 705 0515 - tel: 773.604.8700 - fax: 773.604.4070 - web: www.emberglo.com - e-mail: sales@emberglo.com



726
8474 58
Printed in USA