



Electric Char Broiler E2412

12" Wide Electric Char Broilers

Model	Voltage	Model Number
E2412	208 V Single	5700101
E2412	240 V Single	5700100
E2412	440 V Three Phase	5700105
E2412	480 V Three Phase	5700106

Limited Warranty

The Limited Warranty can be found on www.emberglo.com. To file a claim follow the directions given in the warranty, or contact EmberGlo by mail, phone or e-mail.

4140 W. Victoria Street / Chicago, IL 60646
Phone: 866 705 0514 Fax: 866 580 8700
E-mail: orders@emberglo.com

No equipment may be returned without written authorization from EmberGlo (or Midco International Inc.). Returned goods must be shipped prepaid to the factory.

This warranty does not apply to damages resulting from accident, misuse, abuse or alteration.

CAUTION: This manual contains sufficient information for installation of the EmberGlo Broiler in normal locations.

In the United States, installation must conform with local codes.

CODE COMPLIANCE IS THE SOLE RESPONSIBILITY OF THE INSTALLER.

CAUTION: Cooking equipment should be used in an environment protected by an automatic fire suppression system. Consult the National Fire Protection Association NFPA Code 96 or the latest edition of Standards for Installation of Equipment for Removal of Smoke and Grease-Laden Vapors From Commercial Cooking Equipment.

CAUTION: To avoid grease filter fire hazard, commercial kitchen exhaust hoods should be positioned at a minimum of 3½ feet above the broiler cooking surface, as specified by Commercial Grease Removal, Building Officials & Code Administrators International Inc. and the National Mechanical Code, 1990 Seventh Edition (or latest edition), Article 5, Section M504.0, Table M504.3.2.

WARNING: Additions, changes, conversions and service must be performed by an authorized EmberGlo representative or service agency. Use only EmberGlo specified and approved parts.

WARNING: Improper installation, adjustment, alteration, service or maintenance can cause property damage, injury or death. Read the installation, operating and maintenance instructions thoroughly before installing or servicing this equipment.
FOR YOUR SAFETY
Do not store or use gasoline or other flammable liquids and vapors in the vicinity of this or any other appliance.

PURCHASER: Retain these instructions for future use.

INSTALLER: Inform and demonstrate to the user the correct operation and maintenance of the equipment. Inform the user of the hazards of storing flammable liquids and vapors in the vicinity of this equipment and remove such hazards.

USER: Retain this manual for future reference. If other than routine service or maintenance as described in this manual and associated literature is required, contact a qualified service agency. DO NOT ATTEMPT REPAIRS. An inadvertent service error could result in a dangerous condition.

AVOID ERROR IN PARTS SELECTION. When ordering use complete EMBERGLO Part Number and Description. Furnish Model Number, Bill of Material Number and Serial Number (if available) from the specification plate found on the product.
IMPORTANT: Availability of parts as well as specifications are subject to change without notice. Please consult factory for item availability.



EmberGlo

EmberGlo
A Div of Midco® International Inc.
4140 West Victoria Street
Chicago, Illinois 60646
toll free 866.705.0514
tel 773.604.8700
fax 773.604.4070
web www.emberglo.com
e-mail sales@emberglo.com

SAFETY INFORMATION TERMS: The following terms are used to identify hazards, safety precaution of special notations and have standard meanings throughout this manual. They are printed in all capital letters using a bold type face as shown below, and preceded by the exclamation mark symbol. When you see the safety alert symbol and one of the safety information terms as shown below, be aware of the hazard potential.



DANGER: Identifies the most serious hazards which will result in severe personal injury or death.
WARNING: Signifies a hazard that could result in personal injury or death.
CAUTION: Identifies unsafe practices which would result in minor personal injury or product and property damage.



E2412 - Installation and Maintenance

Installation

Wiring: All units are shipped wired for single phase current.

Ventilation: Do not install broiler closer than 5" to the back or 8" on the side walls. **LEGS SHIPPED WITH THE UNIT MUST BE INSTALLED WITH LEG CHANNELS.** Minimum leg height, with no blockage around the bottom of the broiler, must be maintained for proper ventilation. **FAILURE TO INSTALL OR REMOVAL OF THE LEGS IS A VIOLATION OF THE APPROVAL SEALS AND VOIDS THE MANUFACTURER'S WARRANTY.**

- Remove the leg channels and knobs that are packed in the broiler (located in the hopper front). The leg channels are two long pieces of U-shaped steel designed to prevent warping of the broiler frame when the broiler is moved by sliding on its legs. See Figure 1
- Prop the broiler up and line up the holes in one of the leg channels over the holes for the weld nuts on the front end of the broiler.
- Screw two of the legs provided into the weld nuts to attach the legs and hold the leg channel in place.
- Repeat procedure for the rear legs.

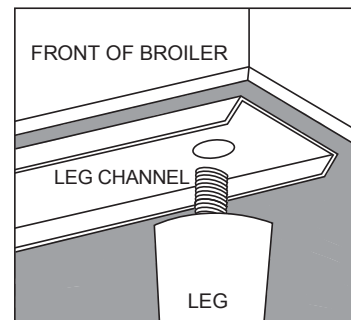

Figure 1 - Leg Placement

Turn the dial to "HI" and preheat for 20 minutes. Dial down to achieve desired cooking temperature.

Preventative Maintenance

NOTE: Always clean the unit starting at the top and working down. Be sure that the grease hopper and grease pan are in place before you proceed with any cleaning procedure in order to prevent any scragging or grease from dropping into the base and onto electrical wiring and terminal blocks.

- With normal use of the broiler, deposits build up on the top and bottom of the grate. In order to assure safe operation, these deposits must be cleaned periodically during the day from both the top and underside of the grill or grate casting.
 - a. To clear the top of the casting, scrape each groove with the tip of the scraper provided until the surfaces are clear.
 - b. To clear the underside of the casting, insert the scraper head through the slots of the grill and turn the scraper handle parallel to the grooves. Pulling upward, scrape deposits from the grill underside. Repeat for each groove.
 - c. Empty grease pan periodically to avoid messy overflow.

Daily Maintenance

- When broiling is finished for the day clean as follows:
 - a. Clean deposits from the top and bottom of the grate as explained above.
 - b. Empty the hopper, clean and reinsert hopper.
 - c. Turn unit to "HI" and leave on for approximately 20 minutes. This will char the remaining grease on the grill casting.
 - d. Turn off controls. When grill is cool, scrape the underside again and wire brush the surface to complete cleaning of the grill.
 - e. Remove and clean the side splash guards and rear trough. Wash the front and rear wells and wipe along the sides.
 - f. Wipe the casting with a dry clean cloth -do not use water or detergent on the castings.
 - g. Empty and clean the grease pan.

E2412 Electrical Wiring Schematic

Schematic

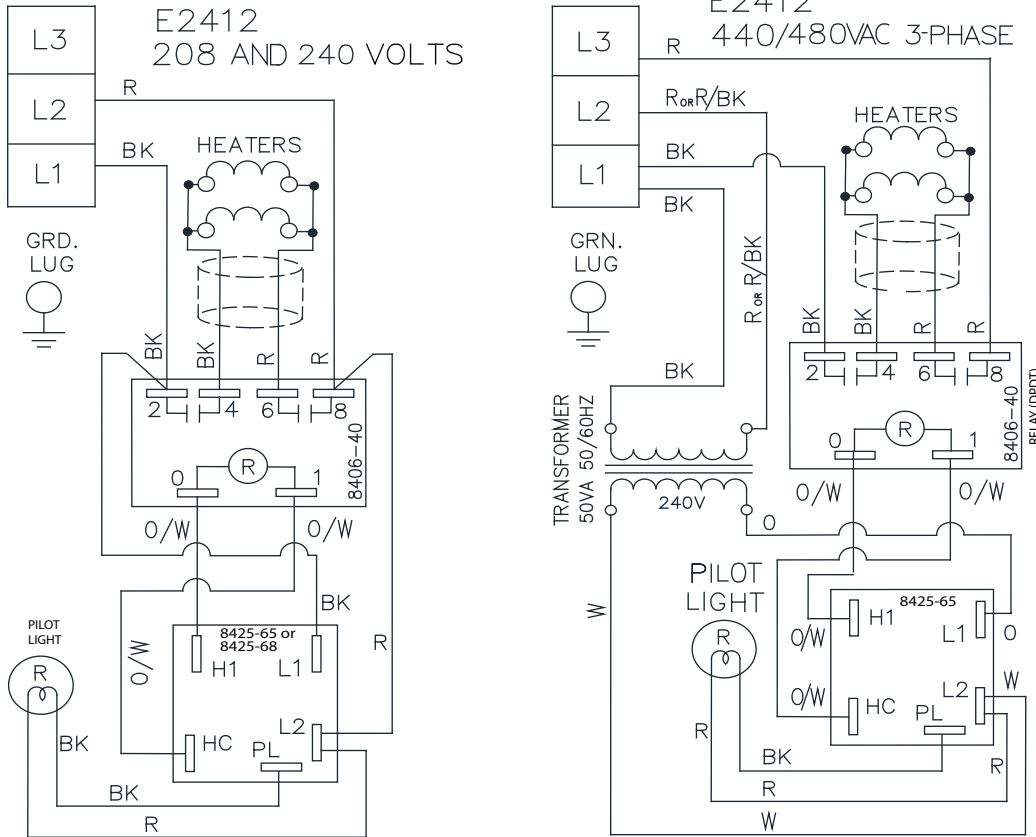

Figure 2 - E2412 Schematics for - 208V, 240V, 440V and 480V

No equipment may be returned without written authorization from MIDCO.

Electric Char Broiler Cooking Guide

... Electric Char-Broiling Grilling Times ...

** Times will vary based upon load size and preference of finished product*

Beef	Thickness	Rare	Med	Well
Filet Mignon, Porterhouse	1"	8	12	16
T-Bone, Club, Rib	1-1/2"	12	16	20
Sirloin	2"	16	22	26
Strip Sirloin	3/4"	6	8	10
Hamburger, Ground Chuck, or Round	1/2"	4	6	8
Shish Kabobs	1"	--	--	18
Skirt Steak	1"	--	--	13

Fish	Thickness	Rare	Med	Well
Fillets (One side without turning)	1/2"			6
	1"			10
Fish Steaks	1"			16
	1-1/2"			20
Fish, whole & dressed	3"			5

Lamb*	Thickness	Rare	Med	Well
Center Cut Loin, Rib	1"	--	12	18
Sirloin Chops, double Rib	1-1/2"	--	17	24
English Chops	2"	--	22	27
Shoulder Chops	1"	--	12	18
Lamb Riblets	1"	--	12	18

*These times can be shortened by partial pre, or post cooking

Poultry	Thickness	Well
Broiling Chickens (ready to broil weight for 1/2 chickens)	3/4 lb	9
Chicken Breasts	1-1/2"	18
	1"	23

Shellfish	Thickness	Well
Shrimp	(Large 12-15/lb)	7
Shrimp Kabobs	(Large 12-15/lb)	10

Pork	Thickness	Rare	Med	Well
Single Chops	1/2"	--	--	18
Double Chops	1-1/2"	--	--	28
Pork Steaks	1"	--	--	15
Pork Tenderloin	1/2"	--	--	14

Vegetables	Thickness	Well
New Red Potatoes (par boiled)		8
Zucchini sliced	1/2"	6
Corn in husk, silk removed		8 to 10
Eggplant sliced	1/2"	9 to 11

EmberGlo cooking capacities for electric char broilers were determined in compliance to UL performance standards. Hamburgers are to be 30% lean, 4" diameter x 1/2" thick. Only 2 patties are cooked per square foot of grill surface. Burgers are cooked at maximum temperature.

Production Capacity: E2412 = 60/hr.
E2424 = 120/hr.
E2436 = 180/hr.

Helpful Hints for the best performance on your Electric EmberGlo Char-Broiler:

Refer to the Electric Char Broiler Cooking Guide brochure - 8474 75E - for more helpful suggestions

1) The temperature at the grill surface, as in all cooking processes, is most important to the quality of food it produces. All units will reach proper broiling temperature with a switch setting of 5 to 5 1/2. This setting will yield between 500° and 550°. The unit will reach broiling temperature in approximately 20 minutes. Any attempt to broil for long periods of time with the controls above 6 may cause meat to burn. Higher temperatures allow for rapid cooking times and marked surfaces that some customers prefer, while low temperatures are for thick cuts of meat that must cook longer without surface excessive charring. Extreme grill temperatures should be avoided.

2) Keeping your grates clean after every broil is important. Old food isn't seasoning - it's crud. A clean grate is less likely to be sticky and will last longer.

3) At the end of the day turn unit to "HI" and leave on for approximately 20 minutes. This will char the remaining grease on the grill casting. Turn off controls. When grill is cool, scrape the underside again and wire brush the surface to complete cleaning of the grill.

4) Always clean the unit starting at the top and working down. Be sure that the grease hopper and grease pan are in place before you proceed with any cleaning procedure in order to prevent any scrapping or grease from dropping into the base and onto electrical wiring and terminal blocks. Empty grease pan periodically to avoid messy overflow.

5) Wipe the casting with a dry clean cloth -- do not use water or detergent on the castings.

E2412 Exploded View & Parts List

Item	Part No.	Description	Qty	Item	Part No.	Description	Qty
1	1612-90	12" Broiling Grate w/out Element	1	10	1615-00	Red Indicator Light	1
2A	1612-03	Broiling Grate w/ Element 208V 1500W	1	11	1604-01	Grease Pan Assembly	1
2B	1612-02	Broiling Grate w/ Element 240V 1500W	1	12	1703-00	E12 Control Panel	1
2C	1612-05	Broiling Grate w/ Element 440V 1500W	1	13	8445-15	Infinite Knob	1
2D	1612-06	Broiling Grate w/ Element 480V 1500W	1	14	1707-01	E12 Hopper Kit	1
3A	1609-50	Element w/out Grate 208V 1500W	2	15	1625-03	Transformer (440V & 480V Units Only)	1
3B	1609-00	Element w/out Grate 240V 1500W	2	16	8408-52	3 Wire Terminal Strip	1
3C	1609-20	Element w/out Grate 440V 1500W	2	17	1610-10	Left Side Splatter Guard	1
3D	1609-30	Element w/out Grate 480V 1500W	2	18	1621-00	Grill Scraper	1
4	1611-00	Element Clamp	6				
5	1711-00	E12 Rear Grease Trough Channel	1				
6	1610-00	Right Side Splatter Guard	1				
7	8450-92	4 Inch Leg	4				
8	1704-00	E12 Leg Channel	2				
9A	1625-04R	Relay & Infinite Switch Kit - 240V	1				
9B	1625-05R	Relay & Infinite Switch Kit - 208V	1				

AVOID ERROR IN PARTS SELECTION. When ordering, use complete EmberGlo part number and description. Furnish model number, bill of material number and date code or serial number from specification plate

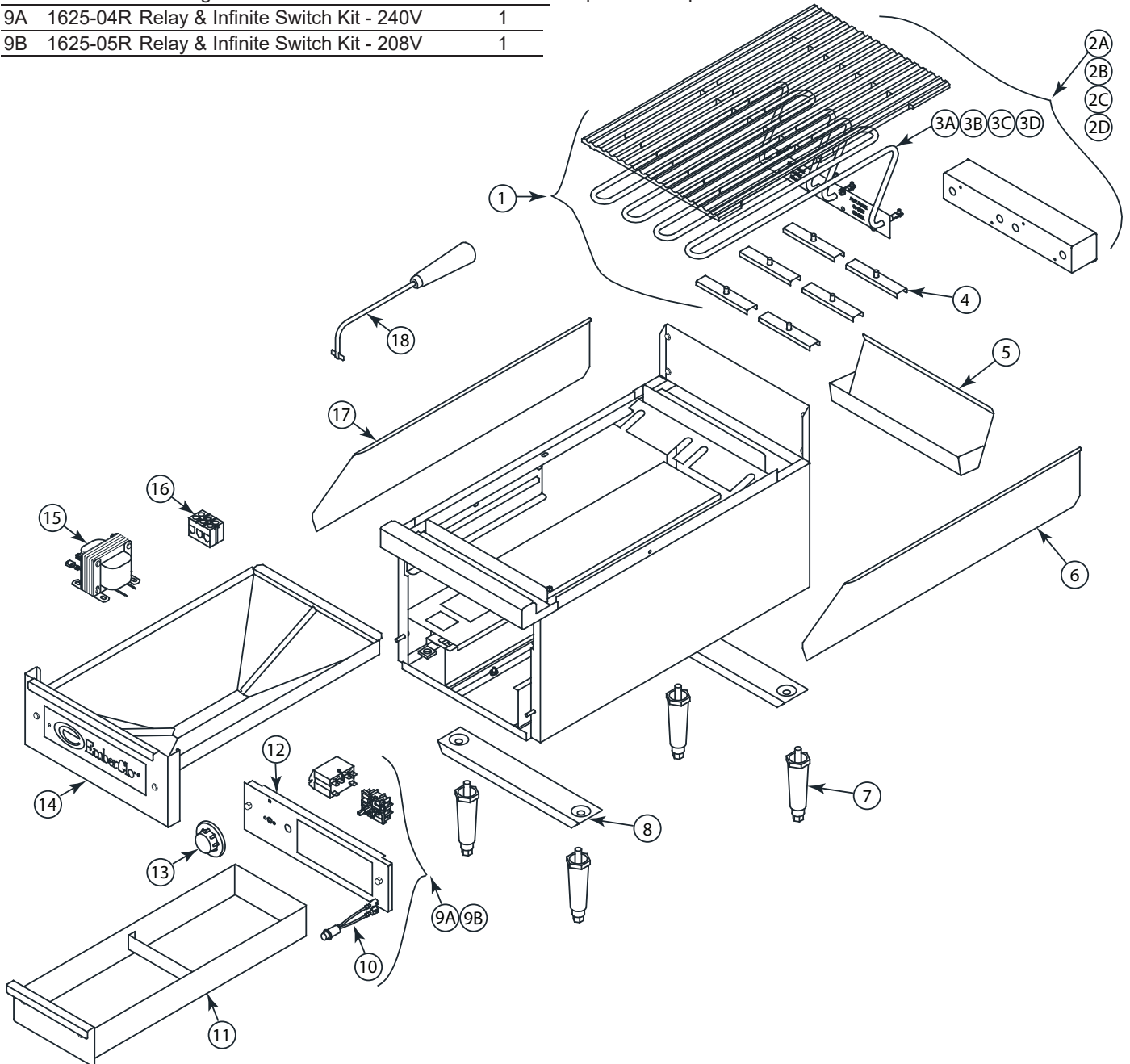

Figure 3 - E2412 Exploded View

Electric Char Broiler E2412 - Installation and Maintenance



EmberGlo A Division of Midco International - 4140 West Victoria Street - Chicago, Illinois 60646
toll free: 866 705 0515 - tel: 773.604.8700 - fax: 773.604.4070 - web: www.emberglo.com - e-mail: sales@emberglo.com

226
8448 97
Printed in USA